

QUALITY, RELIABLE SECONDARY IMPACT CRUSHER

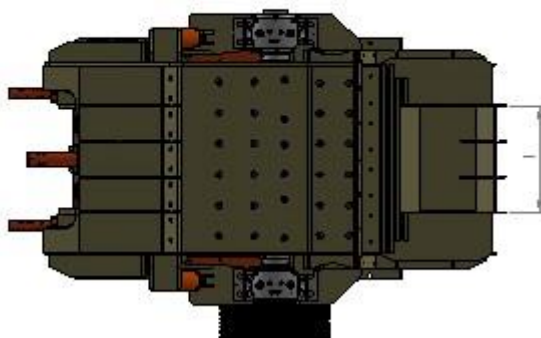
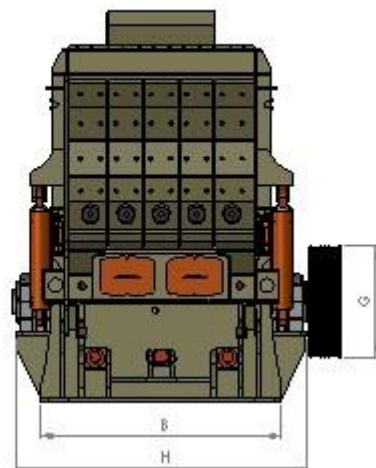
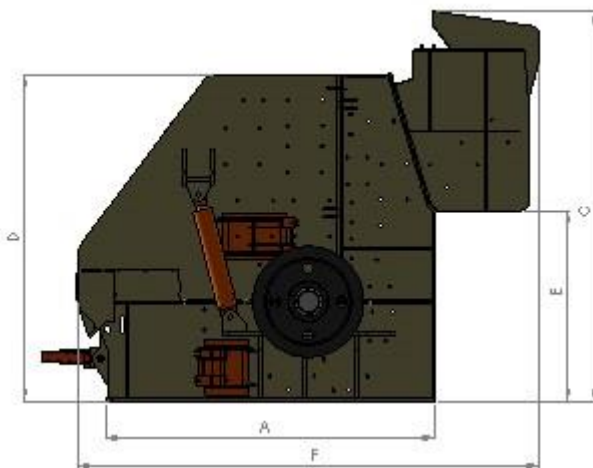
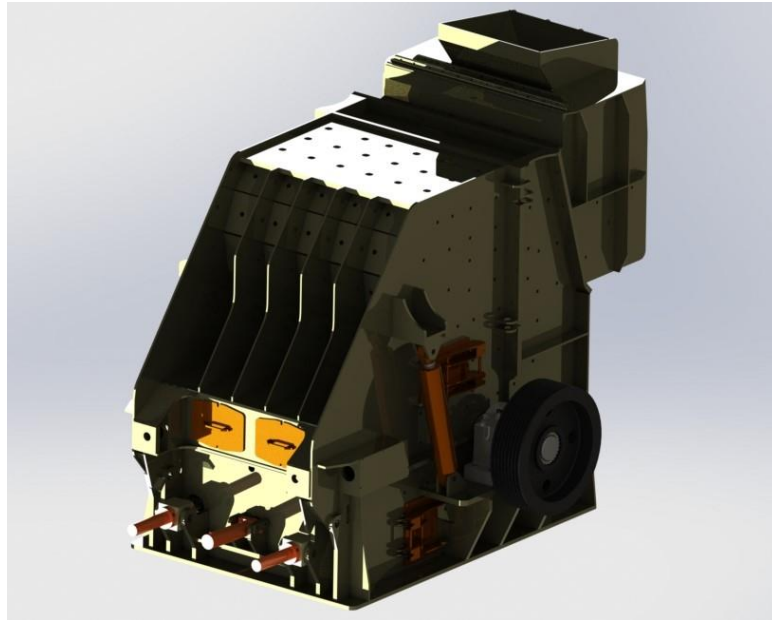

	A	B	C	D	E	F	G	H	I
CSI-1210	2380	1735	2822	2365	1382	3330	800	1860	765
CSI-1212	2380	1735	2822	2365	1382	3330	800	2105	765
CSI-1215	2380	1735	2822	2365	1382	3330	800	2350	1010
CSI-1275	2380	1735	2822	2365	1382	3330	800	1615	765

MAIN FEATURES

- Welded, bolted construction body
- Easy to change screen wires
- Clack front grooves providing flow in the desired direction
- Anti-wear Stone-Box front grooves
- Spare parts and service books
- User and maintenance books

Model	Total Capacity
CSI-1210	140-150 ton/hour
CSI-1212	180-200 ton/hour
CSI-1215	250-300 ton/hour
CSI-1275	110-120 ton/hour

TECHNICAL SPECIFICATIONS

- Movable roller bearing for heavy duty (SKF brand)
- Pitman spring protected trigger
- GS-52 steel casting pitman
- GS-45 steel casting side housing
- 16-18 mangan body protection liner

Model	Engine Power
CSI-1210	160 kW 1500 rpm
CSI-1212	200 kW 1500 rpm
CSI-1215	250 kW 1500 rpm
CSI-1275	110 kW 1500 rpm